



**FEATURES**

- Sensitive sealed crystal element
- Recommended for any string instrument having a sounding board
- Compact, unobtrusive styling

**DESCRIPTION AND APPLICATIONS**

The Electro-Voice Model 805 contact microphone is designed to pick up, for external amplification, music from a guitar, banjo, or any other string instrument having a sounding board. Vibrations of the instrument on which it is mounted are transformed into faithful electrical replicas of the instrument's true sound.

The Model 805 microphone is supplied with a 15-foot single conductor shielded cable and a convenient spring clip which permits attaching the microphone to the instrument without tools or additional hardware.

**SPECIFICATIONS**

GENERATING ELEMENT:	Crystal
IMPEDANCE:	Hi-Z
CABLE:	15-ft. single conductor
ACCESSORY:	Spring clip for mounting
CASE MATERIAL:	Diecast zinc
FINISH:	Satin chrome
DIMENSIONS:	1-1/16 in. by 2-1/4 in. by 27/64 in. (see Fig. 1)
NET WEIGHT:	5 oz.

**CAUTION NOTES**

Crystal microphones should not be exposed to an ambient temperature of more than 112 degrees F. or direct sunlight. Neither should they be left in closed automobiles or show windows in hot weather.

**WARRANTY**

The Model 805 is guaranteed against defects in workmanship or materials for a period of one year. Damage to the crystal element due to exposure to temperatures exceeding 112 degrees F. is not covered by this guarantee.

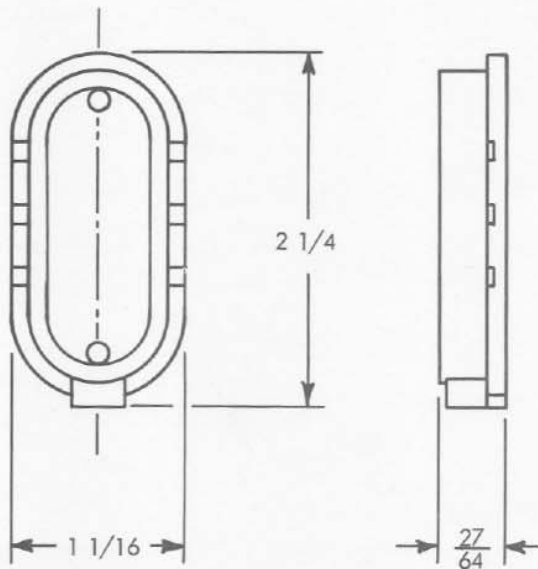

Figure 1 - Dimensions

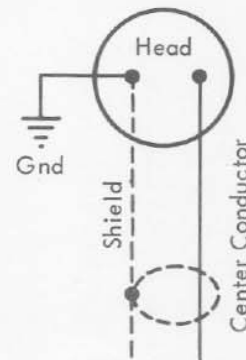

Figure 2 - Wiring Diagram

ENGINEERING DATA MODEL 805 CONTACT MICROPHONE

